

F120 Room Air Cleaning System

SPECIFICATION DATA

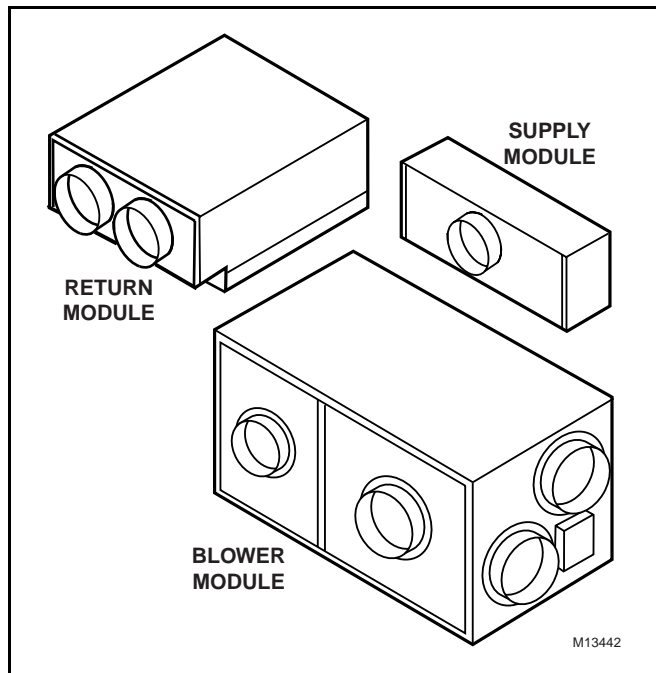

FEATURES

- Specifically designed for use in offices, hospitals, medical clinics, childcare centers, schools, conference rooms, copy centers, laboratories, cafeterias, and hospitality business.
- Ultra-quiet operation allows the system to be used in sound sensitive areas such as conference rooms, offices, classrooms and libraries.
- Modular design of air supply and return allows maximum flexibility when planning the appropriate air recirculation pattern to maximize overall system performance.
- Special return module filter removes both particulates and gaseous contaminants from the air stream.
- Convenient roomside service for all filters.
- Easy-to-change prefilter extends the media filter life.
- Blower module can be mounted remotely from the room to further reduce sound levels.
- Two-speed fan motor allows selecting high or low airflow speeds.
- Optional exhaust feature allows installations to maintain the space at a negative pressure with respect to surrounding areas to prevent contaminants and odors from moving into nearby areas.
- Installation is ideally suited to rooms with either two-by-four or two-by-two foot drop ceiling panels, but can be installed in any wall or ceiling that allows ducting space.

APPLICATION

The F120 Room Air Cleaning System is designed to collect particles by circulating room air through a media filter. When equipped with an optional CPZ module, the system also adsorbs gaseous contaminants and odors.

The F120 exhaust feature is used to maintain the space at a negative pressurization relative to adjacent spaces to prevent contaminants and odors from moving into nearby areas.

The air supply and return design of the F120 allows air contaminants to be filtered at the center of the room with the filtered air returned toward the sides of the room for maximum room air cleaning.



SPECIFICATIONS

IMPORTANT

The specifications given in this publication do not include normal manufacturing tolerances. Therefore, this unit may not exactly match the listed specifications. This product is tested and calibrated under closely controlled conditions, and some minor differences in performance can be expected if those conditions are changed.

Model:

F120 consists of:

- two filtered return modules with a return grille, prefilter, and
- either a 99.97% HEPA filter or a 95% DOP filter and CPZ module;
- four air supply modules with supply grilles;
- a blower module with a two-speed blower, four recirculating air supply openings, four recirculating air return openings and an optional exhaust opening;
- 75 ft (23m) of six-inch diameter flexible duct; 75 ft (23m) of eight-inch diameter flexible duct;

- mounting hardware kit consisting of 12 mounting brackets; 40 ft (12m) of 12-gauge high-tensile strength wire; six standard T- bar mounts; duct tape;
- seven duct collar straps.

Color:

Blower Housing: Unpainted galvanized steel.
Return and Supply Grilles: Off-white

Electrical Ratings:

	120 Vac, 60 Hz		240 Vac, 60 Hz	
	Fan Speed ^a		Fan Speed ^a	
	II (high)	I (low)	II (high)	I (low)
Current (A)	7.0	5.5	3.5	2.8
Power (W)	800	695	800	695

^aOff is "O".

Air Flow Capacity:

Model	Voltage	Efficiency		Gas, VOC, Odor Control Module (2)	Air Vol cfm (cu m/hr)	Air Vol cfm (cu m/hr) ^a
		Particulates at 0.3 micron (DOP Test)	VOC/Odors (First Pass Average)			
F120A 1023	120 Vac 60 Hz	95%	85%	CPZ	900 (425)	1050 (495)
F120A 1031	120 Vac 60 Hz	99.97%	—	—	900 (425)	1000 (472)
F120A 1015	120 Vac 60 Hz	b	b	b	—	—

^a With exhaust option installed.

^b Purchase filters separately.

Filters:

HEPA: High efficiency particulate air (HEPA) filter is 99.97 percent efficient for 0.3 micron particulates when measured with Military Standard 282 DOP test.

DOP: Hospital-grade DOP filter is 95 percent efficient for 0.3 micron particulates when measured with Military Standard 282 DOP test.

CPZ: Sorbent modules contain 11 pounds of sorbent. Adsorbs higher molecular weight hydrocarbons and oxidizes acid gases and lower molecular weight hydrocarbons.

Ambient Temperature Rating:

Shipping and Storage: -20°F to +150°F (-29°C to +66°C).

Operating: Ambient temperatures ≥90°F (32°C).

Can tolerate 104°F (40°C) for brief periods.

Sound Output Rating at 3.3 ft (1m):

High Speed: 52 dBA (below ASHRAE noise criteria (NC) curve specifications for NC45 over speech recognition frequency range of 500 to 2000 Hz).

Low Speed: 45 dBA (below ASHRAE noise criteria (NC) curve for NC35 over speech recognition frequency range of 500 to 2000 Hz).

Installation Weight:

Blower Module: 63 lb (28.6 kg).

Supply Module: (4 required): 8 lb (3.6 kg).

Return Module without filter (2 required): 24 lb (10.9 kg).

95% DOP Filter/CPZ Module (2 required): 21 lb (9.5 kg).

99.97% HEPA Filter (2 required): 10 lb (4.5 kg).

Shipping Weight:

F120 with 95% DOP Filter and CPZ Module: 207 lb (94 kg).

F120 with 99.97% HEPA Filter: 182 lb (83 kg).

F120A1015: 152 lb (69 kg).

F120A1007: 70 lb (32 kg).

Dimensions:

See Fig. 1.

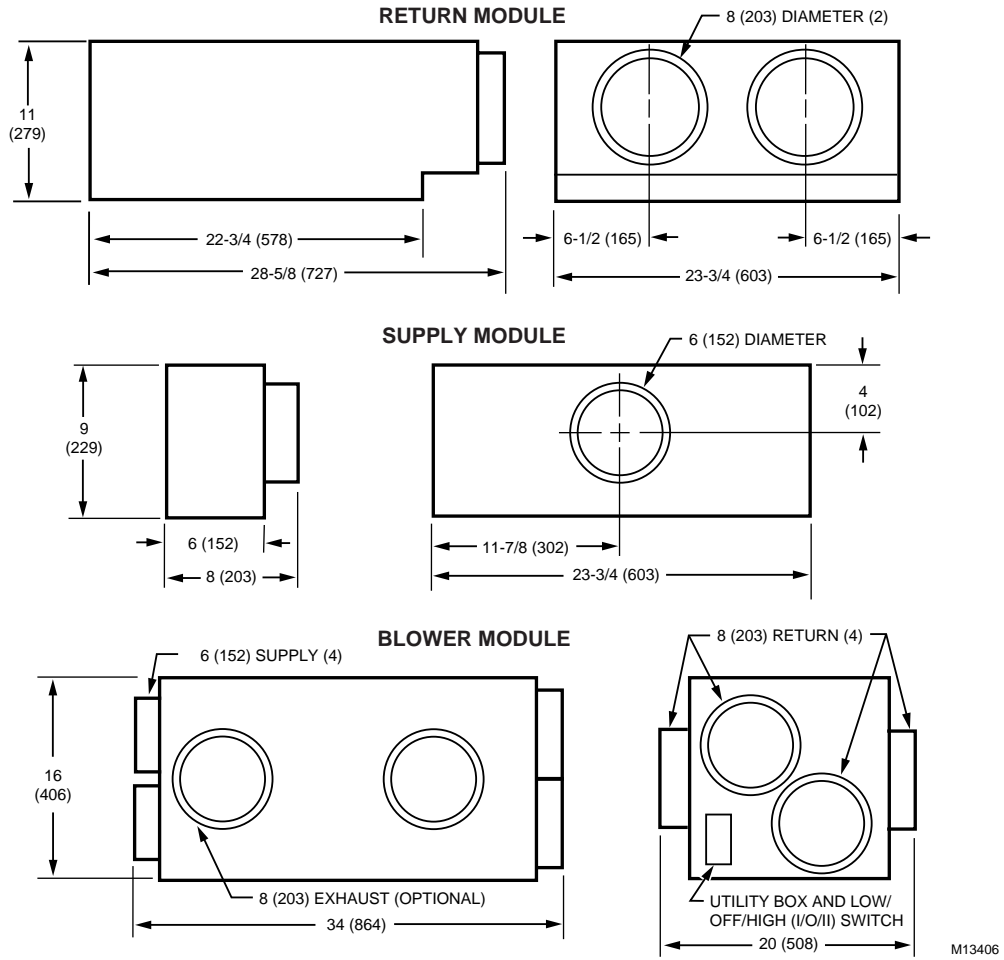

Fig. 1. Approximate F120 dimensions in in. (mm).

Home and Building Control

Honeywell Inc.
Honeywell Plaza
P.O. Box 524
Minneapolis, MN 55408-0524

Honeywell Latin American Region

480 Sawgrass Corporate Parkway
Suite 200
Sunrise FL 33325

Home and Building Control

Honeywell Limited-Honeywell Limitée
155 Gordon Baker Road
North York, Ontario
M2H 3N7

Honeywell Europe S.A.

3 Avenue du Bourget
1140 Brussels
Belgium

Honeywell Asia Pacific Inc.

Room 3213-3225
Sun Hung Kai Centre
No. 30 Harbour Road
Wanchai
Hong Kong

Honeywell